

Flat Panel Speaker System – BM Series  
Dual sided Plane wave speaker

**BM-6002W****BM-6002WH**

Matching transformer internals type speaker

- ※ Sign sheet fixed panel is an Optional.
- ※ This specification may be changed without a notice.

Type	: Dual sided speaker by a single amplifier
Speaker Unit	: Flat Speaker x 2
Impedance	: 4Ω 【※1】
	: 170Ω (100V/60W)
	: 330Ω (100V/30W) } 【※2】
	: 670Ω (100V/15W)
Normal Power Input	: 250W 【※1】
	: 60W/30W/15W } 【※2】
Sound Pressure Level	: 91dB at 1W 1m
Frequency Responce	: 250Hz – 10kHz (-10dB)
Directional Charac.	: Vertical 70° , Horizontal 20° (2kHz -6dB)
Input Connector	: 4-pin cable
Pin Assign	: Red & Light red (+), White(-) 【※1】
	: Red (COM), Light red (170Ω)
	: White (330Ω)、Light White (670Ω) } 【※2】
Cabinet	: SPCC
Mounting	: M10 x 30 Stud Bolt x 4
Dimensions	: W851 x H330 x D90 (mm)
Weight	: App. 14.5kg 【※1】
	: App. 16.5kg 【※2】
Color	: Black (Standard color), Available for Custom colors
Accessories	: M8 eyebolt x 2, M10 nut / washer/ spring washer x 4

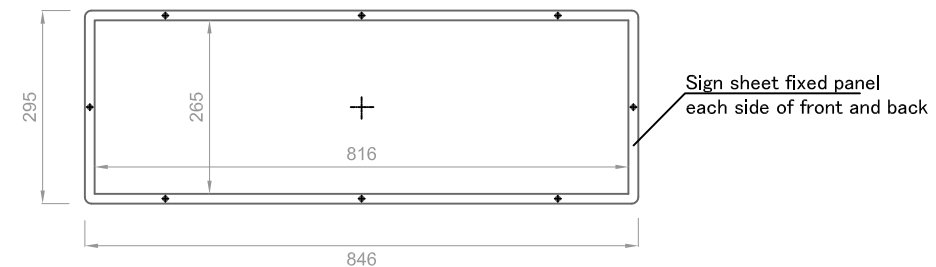
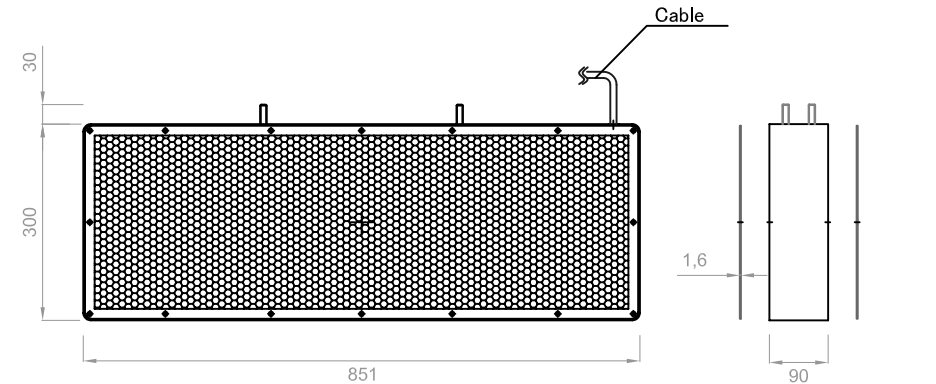
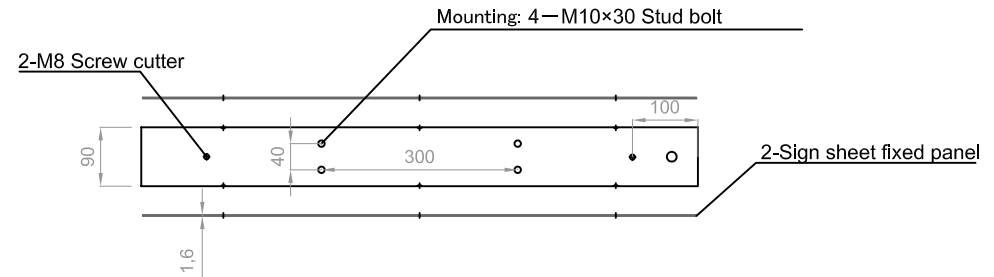

【※1】 BM-6002W

【※2】 BM-6002WH

Itemref	Quantity	Title/Name, designation, material, dimension etc			Article No./Reference	
DRAW.		Checked by	Approved by - date	File name	Date	Scale
		<b>FPS INC.</b> 株式会社エフピーエス			BM-6002W/BM-6002WH	
					Specification sheet	Edition